

371 v2.0

372 v2.0

LUX-RC LAB PRESENTS

Two custom, fully integrated, programmable light engines for portable lighting applications in a very compact 20mm form-factor that incorporate up to 35 Watt main LEDs, secondary color light, lossless PWM-free fully regulated constant current in all modes boost driver and control logic with wireless optical programming, light and motion sensing, user interfaces for power pulse control and electronic button.



Hardware Specification

	371 v2.0	372 v2.0
Input voltage range	One or two rechargeable lithium cells (3.7V nominal, protected or unprotected, ICR or IMR)	Single rechargeable lithium cell (3.7V nominal, protected or unprotected, ICR or IMR)
Absolute Maximum Voltage †	9 Volts	6 Volts
Absolute Minimum Voltage	2.6 Volts ⁽¹⁾	2.6 Volts ⁽¹⁾
Operating temperature Range †	from -40°C to 120°C	
Maximum Output Power	19 Watts with single battery, 32 Watts with two batteries in series	23 Watts with single battery
Maximum Battery Current	4.5 Amp	5.5 Amp
Maximum Regulated Luminous Flux	1800 Lumen ⁽²⁾ with single battery, 2800 Lumen ⁽²⁾ with two batteries	2400 Lumen ⁽³⁾ with single battery
Minimum PWM-free Regulated Flux	Approx. 0.15 Lumen	Approx. 0.2 Lumen
Regulation Type	Boost constant current switching regulator with flicker-free, PWM-free output in all modes and absolutely silent operation. Unlike any FET driver, switching regulator converts power with almost no heat and energy loss, this provides longer runtime and reduces heat dissipated in upper modes.	
Main White LEDs Load Circuit	Three high-power 3.5x3.5mm LEDs in series, 9V output voltage	Six CREE XD16 LEDs two in series, three in parallel, 6V output
Secondary Color LED Current	6.2 mA	8.4 mA
Secondary Colors & Intensity⁽⁵⁾	Deep red 640nm - 0.9 cd ^(5.1) Amber 611nm - 1.3 cd ^(5.2)	Deep red 640nm - 1.3 cd ^(5.1) Amber 611nm - 1.8 cd ^(5.2)
Secondary Color LED Setup⁽⁴⁾	Single high-intensity 0603 LED with build-in secondary lens. The color LED is installed on a tower as close as possible to the flashlight lens and do not interfere with the main LEDs TIR optics providing well-focused (about 60° FWHM angle) and artifact-free round beam pattern	
Standby Current	0.2 mA (typical, with locator beacon active)	
Build-in Protection Circuits	Electronic (FET) reverse polarity protection, the battery overload limiter (5.5 Amp), overheating shut-down (hardware limit @150°C)	
The control logic ADC and sensors	Input voltage meter, PWM-free output modulator, ambient and reflected back light sensor, motion shock sensor, capacity touch sensor.	
The control logic interfaces	1) PPUI (power pulse User Interface) that supports all major tail switches like mcclucky, OR moff switch etc. 2) MOMUI (momentary electronic button) that uses a low-current button connected to a dedicated button port. 3) CSUI (touch sensor), similar to MOMUI but requires a special firmware and hardware sub-configuration.	

⁽¹⁾ Minimal voltage with disabled battery protection and battery stretch function.

⁽²⁾ With three CREE XP-L HI V2 output bin @ 85°C. The actual output depends on the LEDs installed.

⁽³⁾ With six CREE XD16 S3 output bin @ 85°C and fully charged battery. The actual output depends on the LEDs installed.

⁽⁴⁾ The secondary LED also operates as light sensor, this limits the secondary color selection to 530nm...660nm range.

⁽⁵⁾ We offer two secondary LED configurations (specified in order details): hyper red or amber.

^(5.1) Hyper red configuration that uses 0603 APTD1608SEC/J3

^(5.2) Amber configuration that uses 0603 APTD1608SECK/J4-PF

Installation Prerequisites and Heat Dissipation

Mechanical force must be applied to the flashlight lens to minimize thickness of thermal paste and improve heat transfer from the engine to the heat sink

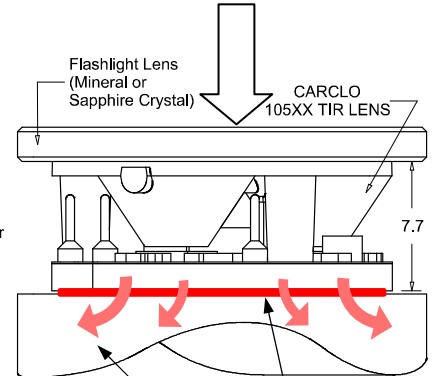

Aluminum or copper heat sink. The sink should be capable to dissipate up to 30W and should not exceed 80°C

A high-performance thermal interface material is essential for reliable operation and high lumen output. We recommend CPU thermal paste such as **Arctic Silver MX-4** or similar. Do not use glue. Do not apply thick layer of paste. A rule of thumb is: the thinner paste layer is, the higher its efficiency. The engine installation surface must be clean flat (polished if possible).

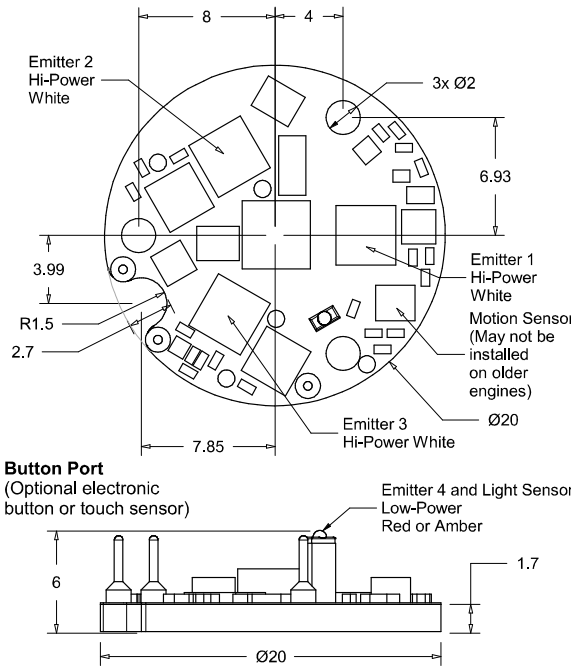
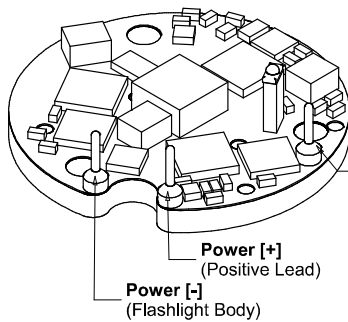
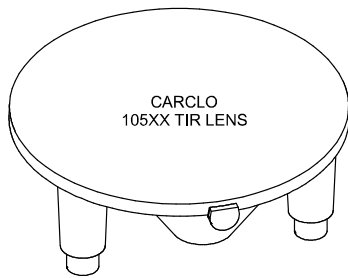

Drawings metric units (millimeters)

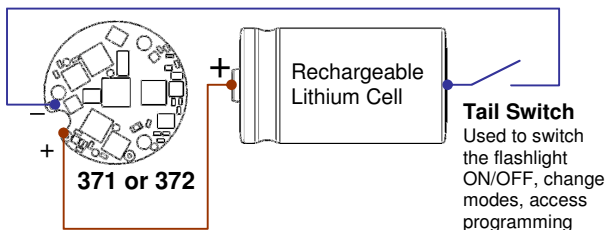

Single battery PPIU flashlight
(classic construction with tail switch)

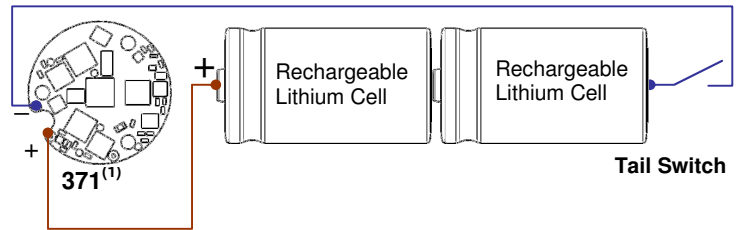

⁽¹⁾ Do not use 372 engine in this configuration!

Two battery PPIU flashlight
(classic construction with tail switch)

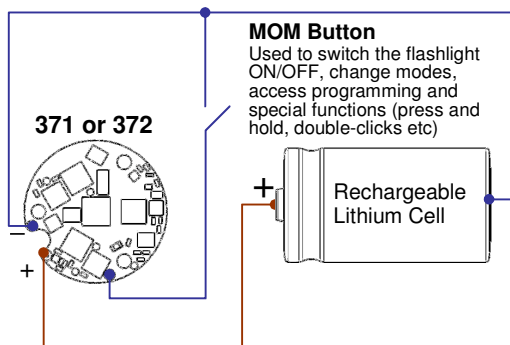

Single battery MOMUI flashlight
(The battery remains always connected to the engine, the flashlight is operated by electronic mom button)

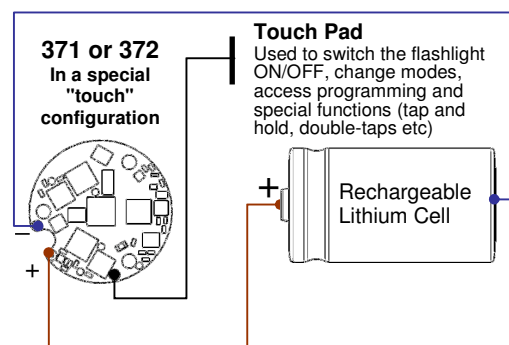

Single battery CSUI flashlight
(The battery remains always connected to the engine, the flashlight is operated by a sensor pad, no mechanical moving parts)

Firmware Overview

Both 371 v2.0 and 372 v2.0 light engines use identical firmware that supports:

- Up to 32 memory modes that grouped into four files, each file features up to 8 memory modes. Each memory mode can be set to any of 64 available output values with wireless optical programming tool at lux-rc.com. The whole range of output modes consists of: "not used" value, 33 fully regulated white modes, secondary color mode, S.O.S. signal and programmable color or white signal (or beacon) generator that results into 28 possible patters.
- Each of four memory files features individual memory, battery, temperature, PPUI timeout and bounce switch configuration that is set by wireless optical programming.
- Each of four memory files also features offline programming register that consists of seven switches that are selected with individual PINs and do not require internet access for programming. The switches register consists of: motion sensor ON/OFF switch and timing profile selector, standby locator beacon ON/OFF switch, new modes layout (8 modes in one line) or legacy modes layout (4+4 modes in two lines) selector, standby mode with locator beacon for power pulse UI ON/OFF switch, double-click configuration switches.
- The active file is selected by short PIN 4 with power switch or by "4-click and hold" with momentary electronic button. Wireless programming and offline register switch change affect only the currently selected file. The file selector starts with the current file number and then scrolls through all four files. The last file that is shown before you switch the engine off (or release the momentary button) is saved and becomes new active.
- In addition to 32 modes that is programmed by user, momentary button UI offers four predefined instant access modes that is selected and accessed by button press-and-hold: white turbo (aka "afterburning"), color mode, white moonlight and defense strobe (10Hz).

Program Memory Organization

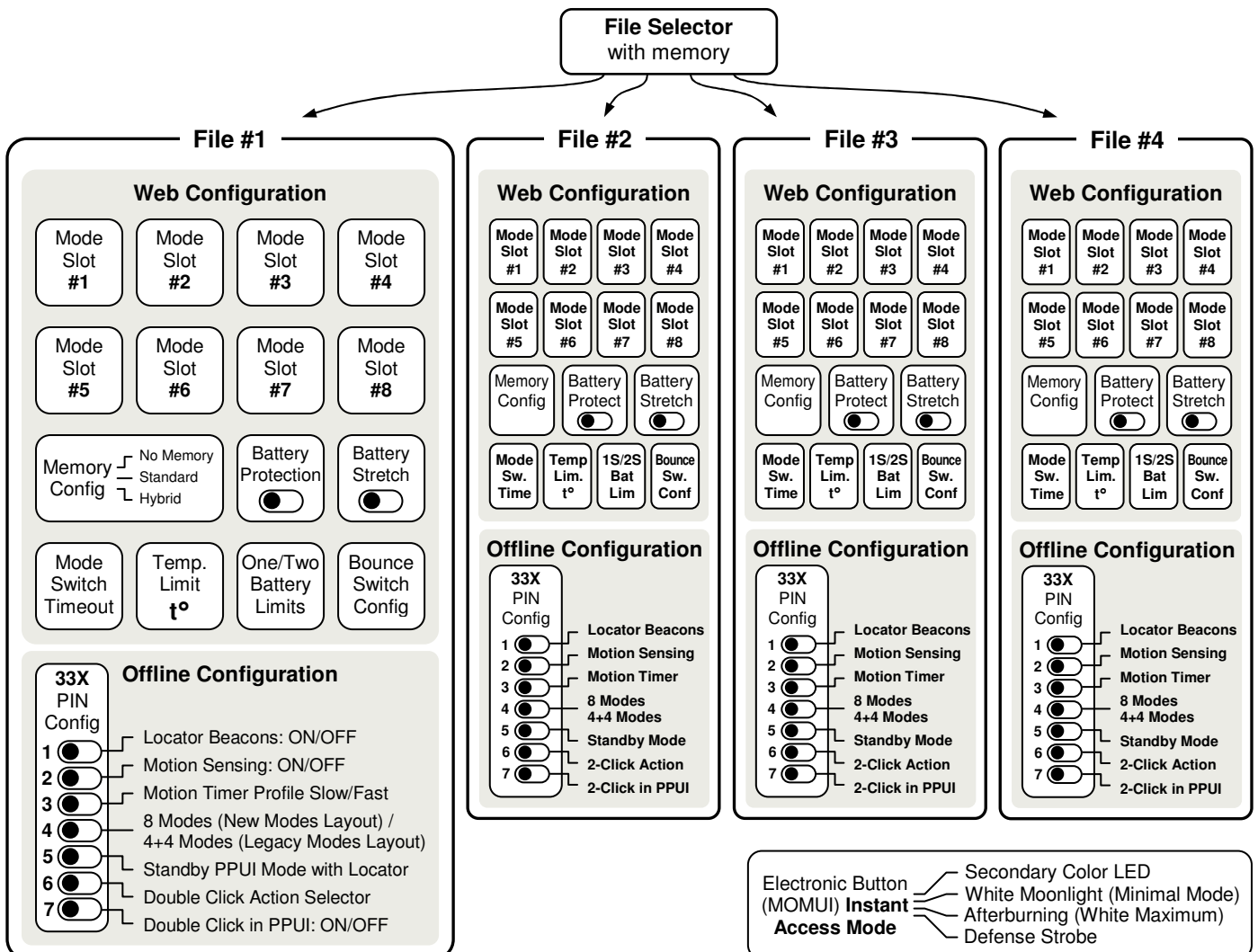

New Firmware Features

	371D <small>(see note 1 below)</small>	371 v2.0 and 372 v2.0
Programmable memory modes	4 modes - single battery setup 4 modes - two battery setup	Up to 32 modes in 4 configuration files, 8 modes in each file
Wireless optical programming	Basic wireless programming with NXS tool at lux-rc.com.	Extended wireless programming with NXS tool at lux-rc.com. New features added: temperature limit, mode switch timeout.
User interfaces	1) Power pulse UI (mcclicky, twisty etc) 2) Momentary aka electronic button UI (basic functions)	1) Enhanced power pulse UI (file selector, configurable double-click, standby mode with locator beacon) 2) Enhanced Momentary aka electronic button UI (4 instant access modes, file selector, configurable double-click) 3) Touch pad UI (special hardware configuration)
Battery support	Rechargeable and primary lithium cells, one or two. Programmable battery protection and battery runtime stretch.	Rechargeable and primary lithium cells, one or two. Programmable battery protection and battery runtime stretch. 372 supports only single-battery setup.
Memory options	No memory, standard memory and hybrid memory.	Each of 4 files can be configured to operate on its own memory mode: memory off, standard or hybrid memory.
Reflected light sensing (aka bounce switch)	Available after calibration (by setting the sensitivity level)	Available after calibration (by setting the sensitivity level)
Motion sensing	Basic support added in v1.3 (2019)	Enhanced support with configurable timer
Voltage meter	Displays the battery voltage	Displays the battery voltage
Battery quality tester	Not implemented	Displays the battery quality in a five-star format after automatic load testing
Standby mode with locator beacon	Implemented only in momentary (electronic) button UI	Standby mode with configurable memory is introduced in power-pulse UI (mcclicky, twisty etc). Locator beacon can be enabled or disabled with a PIN code.
Double-click support	Not implemented	Implemented in all user interfaces, including power pulse UI. Can be configured to jump to the final mode (highest mode number) or to navigate the modes in reverse order.
Offline programming	These options are set with PIN codes (require no web to program): locator beacon on/off in standby, motion sensing on/off.	These options are set with PIN codes (require no web to program): locator beacon in standby modes (any UI), motion sensing on/off and motion sensing timer selection, 8 modes or legacy 4+4 modes layout, standby mode on/off and double-click configuration.
Standby beacons	<ul style="list-style-type: none"> • Double red beacon in standby mode (supported only with momentary aka electronic button) 	<ul style="list-style-type: none"> • Single red beacon in standby mode in both mcclicky/twisty and electronic button setups. The beacon can be disabled by PIN code. • Double red beacon in motion tracking hibernate mode (the flashlight is ready to start as any motion or carry is detected)

Note 1. 371D is the previous generation of LUX-RC 20mm fully regulated triple engine for advanced flashlights. 371D and 371 v2.0 are built on the same hardware platform. In most cases legacy 371D boards can be upgraded to 371 v2.0 with no functionality loss by reprogramming the engine MCU. This procedure requires full physical access to the board with special instrument and cannot be done with NXS wireless optical interface. Old 371D engines released before 2019 had no motion sensor installed. Upgrading such engines is also possible but motion sensing will not be available and motion sensing PIN must be set OFF.

Factory Default Configuration

The factory configuration consists of all four files preloaded and optimized for the specific product. Also, a 3rd party vendor may offer its own factory configuration. Flashlight owner is allowed to reprogram the engine without any restrictions. Any of four files can be reprogrammed with wireless optical programming tool at www.lux-rc.com and with PINs that affect the offline switches. LUX-RC products are shipped with the following factory files:

File #1	File #2	File #3	File #4
8 modes of white from moonlight to full maximum with standby locator. Twisty configuration also includes color mode. Battery protection and stretch is active. Memory is ON. Motion sensing is active.	8 modes of white in reverse order from high to low with standby locator. Twisty configuration also includes color mode. Battery protection and stretch is active. Memory is ON. Motion sensing is active.	Tactical file. Two white modes: 200LM and turbo. Twisty configuration also includes color mode. No memory. Battery protection with stretch is active. No locator, no motion sensing.	Signals file. Defense strobe, three high-intense white beacons, SOS, two red beacons, red strobe. Battery protection without stretch. Memory is ON. No locator, no motion sensing

PINs Purpose and Timing

PINs were introduced to access programming, change memory files, run applications and configure the engine with no access to optical wireless programming. PINs are entered by switching the flashlight ON and OFF with the tailcap master switch. PINs cannot be entered with electronic momentary button. Most PINs consist from three "digits". To avoid interfering with normal flashlight operation PINs use special timing:

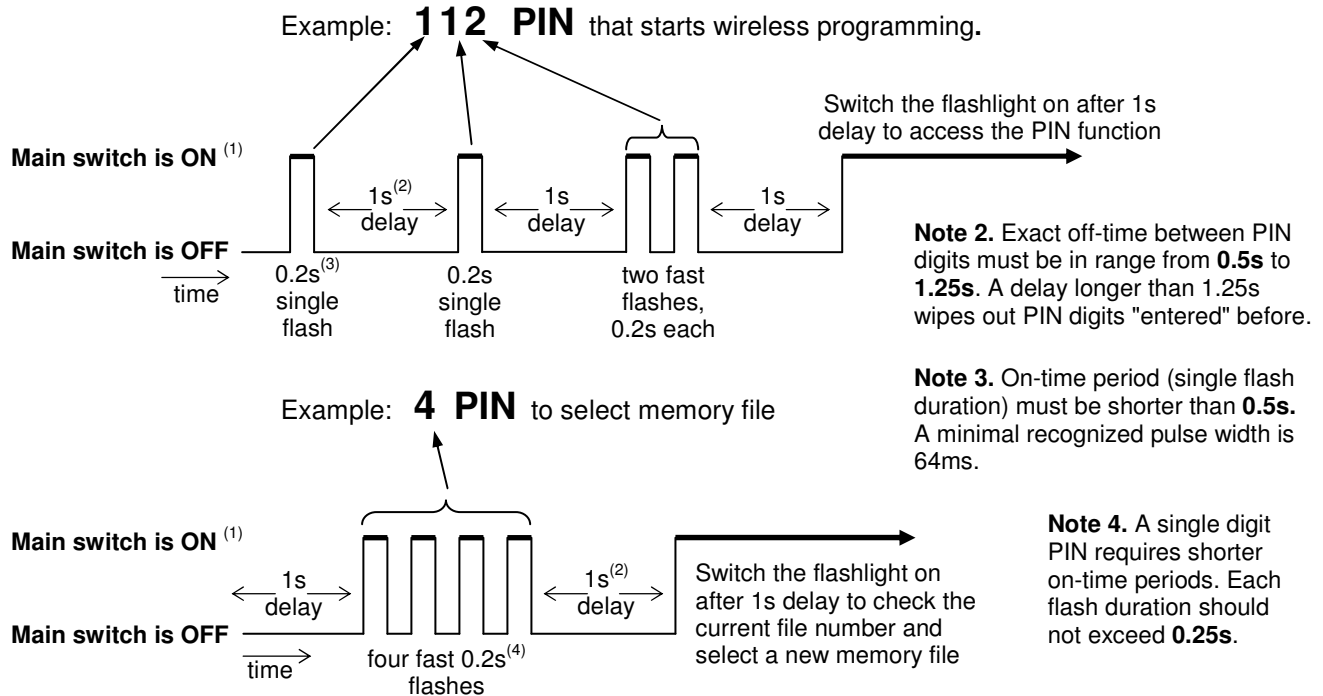

Note 1. Switching on normally activates a mode. Depending on the flashlight programming it can be white or color mode. In some cases you cannot see any light during short ON period. This may happen with signal modes like beacons, SOS etc. Also, if the standby locator mode is active, the 1st flash is not visible but still counts. When you enter the PIN direct the flashlight out of your eyes to avoid blinding. Just count the clicks and make second delays between the figures. Do not rely on the flashing feedback.

All PINs Overview

4⁽¹⁾	Shows the current memory file number and selects a new file.
111	Voltage meter application. Returns battery voltage in format whole number plus tenths.
112	222 Starts wireless optical programming. The engine reads the program data from your smartphone screen after the configuration is done with online application at www.lux-rc.com .
113	Battery examination application. Performs automatic load test and returns battery rating in format from one star (the worst) to five star (excellent battery).
311	Shows all bits of the offline configuration register. All seven switches are shown subsequently in format: red flash when switch is off and white when it's on.
331	Locator beacon in standby mode: ON - single white flash. OFF - single red flash.
332	Motion sensing: ON - double white flash. OFF - double red flash.
333	Motion sensing timing profile: slow timing - three white flashes, fast timing - three red flashes.
334	Mode number configuration: new layout with 8 modes in one line - four red flashes, legacy 4+4 modes in two lines - four white flashes.
335	Standby mode with locator beacon for twisty/mcclicky flashlights: ON - five white flashes. OFF - five red flashes.
336	Double-click action configuration. Six white flashes: double-click performs a jump to the farthest mode in the list of all modes with option to return back after subsequent double-click. Six red flashes: double-click changes mode in a reverse direction (mode rewind function).
337	Double-click support in twisty/mcclicky flashlights: ON - seven white flashes. OFF - seven red flashes. Note that in momentary button configuration double-click is always enabled.

Note 1. Some 3rd party vendors may use "114" PIN instead of "4" to access the file selector.

Memory File Selection Procedure

Twisty and McClicky flashlights must use PIN "4" to access the file selector application. It starts with the current file number and then loops through all subsequent files. Switch the flashlight off to select the last shown file number. All configuration changes will apply to the file which is active now. A 3rd party vendor flashlight may use "14" PIN instead of "4" PIN to change the files.

Momentary (electronic) button flashlights in addition support a shortcut: from standby mode (the flashlight is off) perform fast three clicks then press and hold the button: the flashlight starts with the current file number, then loops through all subsequent files. Release the momentary button after the file number you want to select and save.

Voltage Meter Application

Twisty and McClicky flashlights must use PIN "111" to run voltage meter. It supports both single battery and two battery setups. In case of two batteries the voltage meter shows average voltage (the engine input voltage is divided by 2). The voltage is shown as a sequence of flashes. The whole part is shown in white color. The tenth is shown in red. For example "3.6 volts" is shown as three whites and six reds. The battery voltage reflects the charge. A fully charged battery is 4.2 volts. Battery is depleted when voltage drops below 3.0 volts.

Momentary (electronic) button flashlights in addition support a shortcut: use four fast clicks from standby mode to lock the button. When button is locked, clicking has no effect. In this mode press and hold the button for two seconds. After the voltage is shown to continue normal operation use four fast clicks to unlock the button.

Wireless Optical Programming

Twisty and McClicky flashlights must use PINs "112" or "222" to program modes with online application at www.lux-rc.com. In programming mode the engine tries to read data from smartphone or computer screen. A dim red light indicates that the engine is in scanning mode. After successful reading the light is switched off. For more details on the programming options please refer NXS programming tool at www.lux-rc.com.

To access programming with momentary button disconnect the battery (unscrew the tailcap for several seconds). Press and hold the momentary button. While the button is pressed down, connect the battery by screwing the tailcap. A dim red light will indicate that scanning mode active and the engine is ready for programming.

Battery Test Application

To take advantage of full potential of 371 and 372 engines, make sure your battery complies the highest quality standards. Use only a fully charged battery for testing. You can test only one battery. Use PIN "113" to start the battery test. Fast red flashing means the test fail, in this case recharge the battery and try again. The test starts with gradual increase of brightness. The engine measures the voltage drop across all modes and calculates the battery internal resistance. A good battery features minimal voltage sag under a heavy load.

Battery rating is shown in a five-star format. Note that a specific flashlight wiring and switch resistance also affect the rating. A higher wiring resistance and a weaker switch lead to higher heating loss in turbo mode and is reflected by a lower rating.

Offline Configuration Switches

Seven switches are associated with each memory file and used to configure special features that do not require internet access. Changing memory file also changes the offline configuration. To toggle an offline switch use PIN in format "33n", where "n" is the feature number. Example: motion sensing feature number is "2". So PIN "332" switches motion sensing ON and OFF. After "33n" PIN is entered, the engine confirms the change by a series of flashes. Number of flashes is "n" and equals to the feature number. PIN "311" shows all switches status. It's displayed as a series of seven flashes. Both "33n" and "311" PINs use red flash when feature is OFF and white when it's ON:

Offline configuration switches: PINs "33n" and "311"

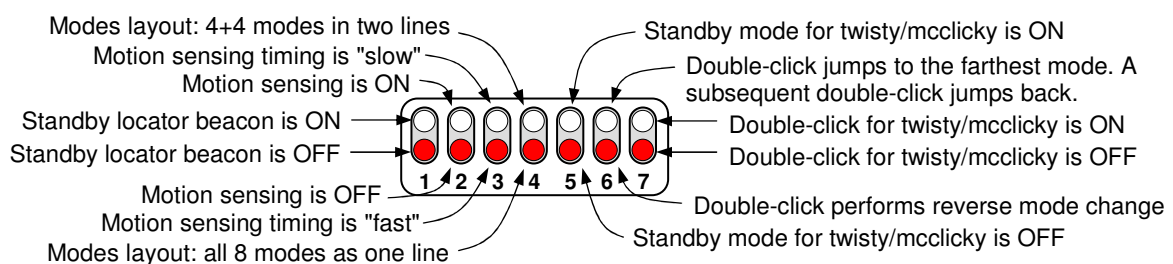

Motion Sensing

371 and 372 engines use a shock sensor to operate the flashlight in addition to the button control. When enabled, the motion sensor logic steps the brightness down after a period of inactivity. If no motion is detected during longer period of time, the light is switched off and operation continues in Hibernate mode. In Hibernate mode the flashlight continues motion tracking but sensitivity is reduced. Double flash color locator indicates that motion tracking is active and after a more intense shaking or carry during several seconds the flashlight returns to normal operation (last used mode). PINs "332" and "333" are used to control and configure the motion sensing:

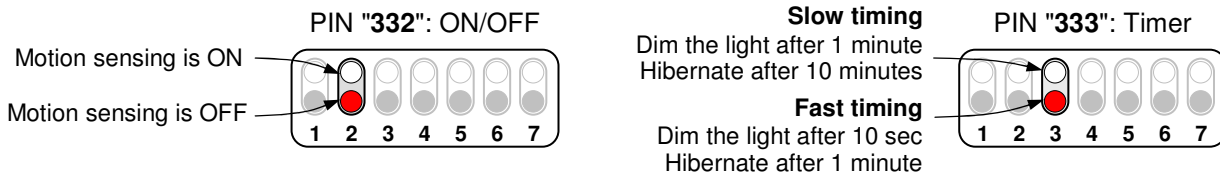

Locator Beacon in Standby and Hibernate Modes

Locator beacon helps to find flashlight in dark environment when it's in standby mode or in Hibernate with motion tracking. A single-flash color beacon is active in standby mode when it's enabled in offline configuration, PIN "331" controls this feature. A double-flash color beacon is active in Hibernate mode. The double-flash beacon cannot be disabled.

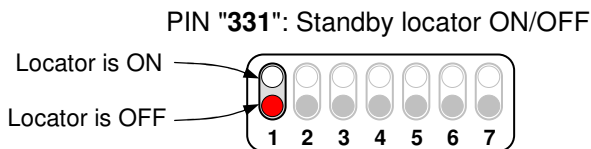

Mode Number Layouts

Version 2.0 introduced a new modes layout: all 8 modes in one line. Unlike legacy mode layout when modes were grouped in two lines, four modes each, the new single line layout doesn't depend on the battery count. PIN "334" controls the modes layout:

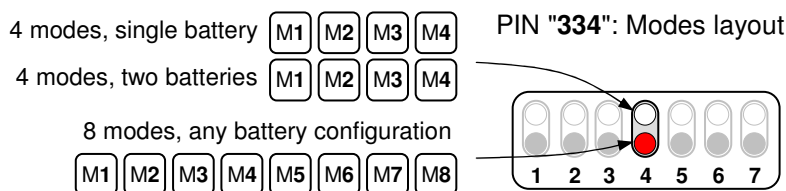

Standby Mode in Twisty/McClicky Flashlights

Standby mode is now implemented also in twisty/mcclicky flashlights. Similar to MOMUI, when the flashlight is in standby mode it consumes almost zero power and may stay in this mode for months with minimal battery discharge. Flashing standby locator beacon can be enabled in standby mode. Standby mode is selected after a "long half-click". A "short half-click" in standby mode resumes normal operation. Depending on the memory settings flashlight may return to the last mode (memory is ON) or start from the 1st mode (memory is OFF). PIN "335" controls standby feature:

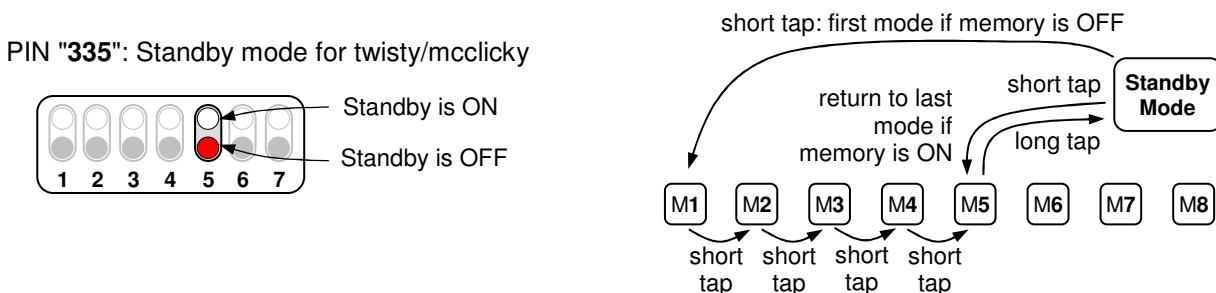

Double-click Support

Two PINs control double-click function. PIN "336" sets the double-click action. PIN "337" enables and disables double-click support in twisty/mcclicky flashlights. Note that double-click is always enabled in momentary button flashlights.

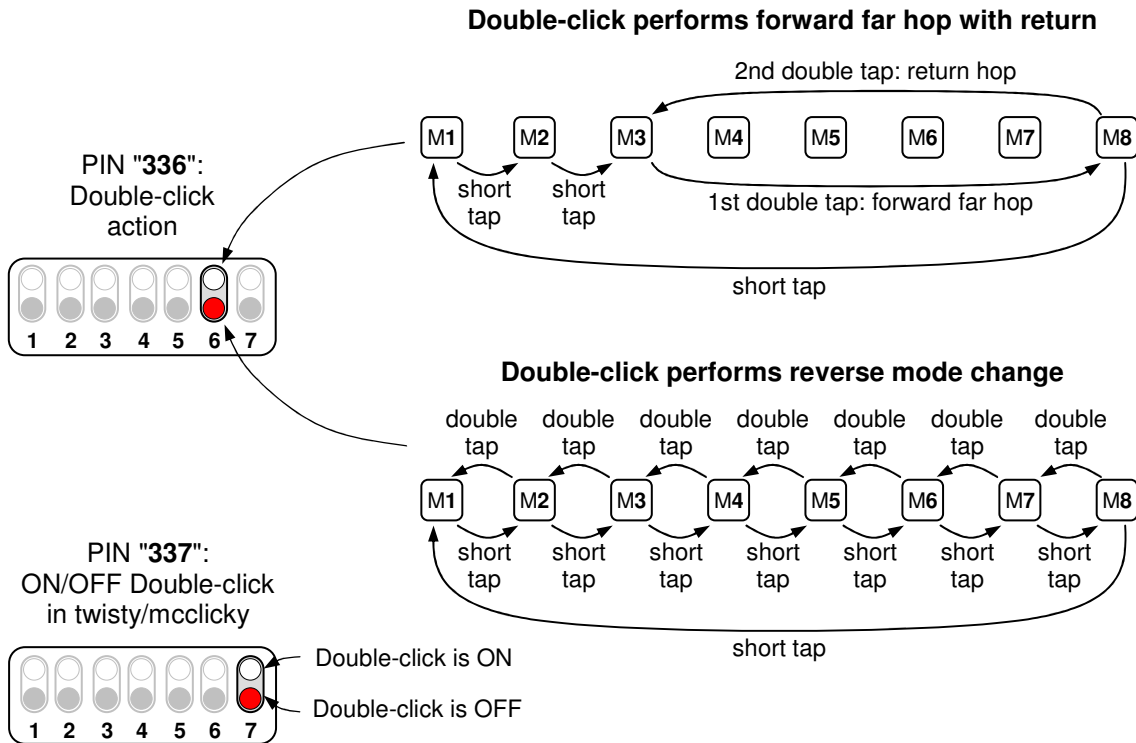

Momentary Button User Interface

Momentary button UI supports all PINs and features described above. In this configuration the engine is never disconnected from battery. Due to momentary (electronic) button specifics it provides more functions than twisty/mcclicky UI:

Switch the light ON/OFF	Use a short click to switch the light ON and OFF. Depending on the memory configuration it starts from the first mode or the last used mode. The clicking may have no effect if the button is locked. When the light is OFF it remains connected to the battery and may run locator beacon signal. The locator can be disabled with PIN "331".
Mode change (normal order)	Press and hold the button when the light is ON to change the modes. Keep the button pressed to loop through all modes configured in the current file.
Mode change in reverse order	Double-click the button to change modes in reverse order. This action requires the PIN "336" to be set off (red).
Jump to the farthest mode in the list	Double-click the button to jump directly to the farthest mode in the list of all modes of the current file. Subsequent double-click returns to the original mode. This action requires PIN "336" to be set on (white).
Instant-access mode (color moonlight)	Press and hold the button in standby mode to run "instant-access" mode. By default the "instant-access" mode is set to color moonlight.
Change and save an instant-access mode	Press and hold the button in "instant-access" mode to loop through all variants available: red and white moonlights, turbo and defense strobe.
Lock/unlock the button	Do four fast clicks in standby mode to lock/unlock the button.
Check battery voltage	Lock the button by four clicks and then press and hold the button during 2 seconds.
Change memory file	In standby mode perform four fast clicks and do not release the button after the 4th press. Keep it pressed until you see the number of file you want to set active.
Run wireless programming	Disconnect the flashlight from the battery. Press and hold the button, do not release it when you connect the battery. Dim red light will indicate when the engine is ready to read program data from smartphone screen.

Engine Serial Number

Each engine has unique serial or batch number which is shown as a sequence of red flashes in programming mode. Batch number is a common number of a batch of absolutely identical boards built in the same date. With the serial number you can check the configuration details at www.lux-rc.com that include: main LEDs full part number, production date, hardware and firmware versions, ownership and service history if any.

To access programming mode use PINs "112", "222" or refer to a procedure described above for momentary button. In programming mode the engine tries to read program data from smartphone screen with the light sensor. When no program data is detected for several seconds, the engine displays the serial number by a series of bright color flashes with one second delay between figures. Serial number normally starts with the build year (last two figures) and the build date quarter (from 1 to 4). The least three digits are batch, version and revision numbers. For some products serial number may use a special custom format not described in this document.

Standard serial or batch number format

